

RECOMMEND P.C.B LAOUT
TOLRANCE±0.05

- PAD
- NO TRACE,NOTEST POINT
NO VIA HOLE,NO GROUND AREA

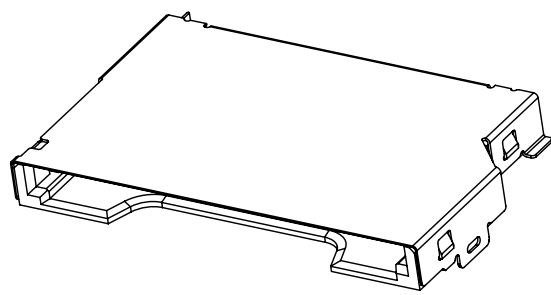

PART.NO.:
SD45-AN401-**

NOTES :

1. MATERIAL :
 - 1.1 HOUSING:LCP UL94 S475 V-0, BLACK COLOR.
 - 1.2 SHELL:STAINLESS STEEL.
 - 1.3 CONTACT:COPPER ALLOY.
2. FINISH :
 - 2.1 CONTACT: GOLD PLATING ON CONTACT AREA,
MATTE TIN 80u"MIN ON SOLDERTAIL AREA.
50u" MIN NICKEL PLATING OVERALL.
 - 2.2 SHELL: 30U" MIN SOLDERABLE NICKEL PLATED OVER ALL.
3. ELECTRICAL CHARACTERISTICS:
 - 3.1 OPERATING VOLTAGE : 100V AC(rms)/DC.
 - 3.2 CURRENT RATING : 0.5 A.
 - 3.3 OPERATING TEMPERATURE: -25°C~+85°C.
 - 3.4 CONTACT RESISTANCE: 100 m OHMS MAX.
 - 3.5 INSULATION RESISTANCE: 1000M OHMS MIN. AT 250VDC.
 - 3.6 DIELECTRIC WITHSTANDING VOLTAGE:500 VAC/1MINUTE.

- 42: 功能区镀金1U", 锡脚镀雾纯锡100U"
- 43: 功能区镀金3U", 锡脚镀雾纯锡100U"
- 44: 功能区镀金5U", 锡脚镀雾纯锡100U"
- 45: 功能区镀金10U", 锡脚镀雾纯锡100U"
- 46: 功能区镀金15U", 锡脚镀雾纯锡100U"
- 47: 功能区镀金30U", 锡脚镀雾纯锡100U"

PIN NO.	PIN DEFINE
P1	CD/DAT3
P2	CMD
P3	VSS1
P4	VDD
P5	CLK
P6	VSS2
P7	DAT0
P8	DAT1
P9	DAT2
P10	CD
P11	W/P
P12~15	GND

WITHOUT CARD		CARD INSERTED: LOCK		CARD INSERTED: UNLOCK	
W/P	GND	W/P	GND	W/P	GND
C/D	VSS1	C/D	VSS1	C/D	VSS1

GENERAL	TOLERANCE	DWG.NO.	SD45-AN401-**	PART.NO.	SD45-AN401-**	DRAWN	L.M.J 2018.09.13	UNIT	mm	SCALE	ND SCALE
.x±0.50	.x ± 5°	REV.	A	TITLE	SD No Push H2.80-2 conn.	CHECKED		东莞市欧联电子科技有限公司 DONGGUAN OLN ELECTRONICS TECHNOLOGY CO., LTD.			
.x±0.25	.x ± 2°	SIZE		SHEET	1 OF 2	APPROVED					
.xx±0.15	.xx ± 1°	A4									

东莞市欧联电子科技有限公司

包装作业规范

REV.	ECN.NO.	MODIFY.CONTENT
------	---------	----------------

包装作业图示及说明 (PACKING OPERATION DIAGRAM & INSTRUCTION)

- 一.
- 1) 将成品一一放入REEL包装盘内,依同一方向放入.
 - 2) 包装时,如图所示.
 - 3) 一个REEL包装盘放置300个成品.

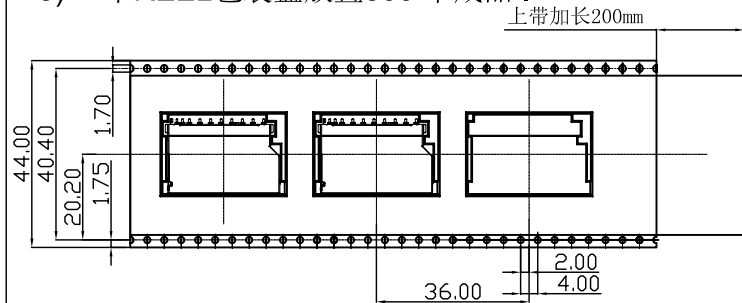

- 三.
- 1) 每箱装 6 盘REEL包装盘.
 - 2) 每箱放置 1800 PCS 的成品.

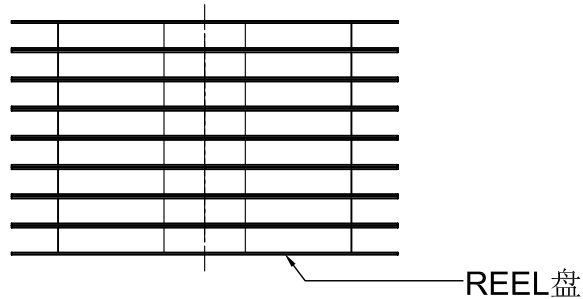

- 四.
- 1) 用TAPE将纸箱封实.

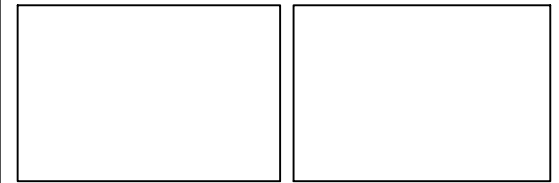

- 二.
- 1) 装盘前先把前面空20pcs产品,然后再开始装盘, 尾端也需空10pcs产品,上带加长200mm.
 - 2) 装满成品的REEL包装盘如下图所示.

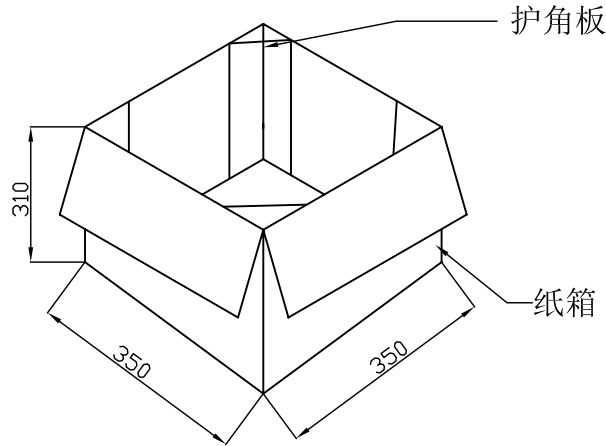
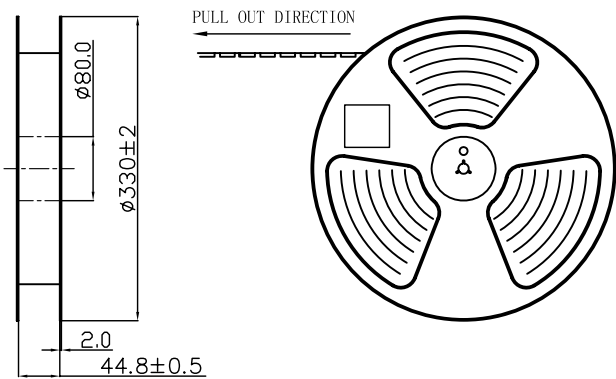

備註 (REMARK)

1. 若有未裝滿之零數箱,必須以緩衝材塞滿.

GENERAL TOLERANCE	TOLERANCE	DWG.NO.	SD45-AN401-**	PART.NO.	SD45-AN401-**	DRAWN	L.M.J 2018.09.13	UNIT	mm	SCALE	ND SCALE
.x±0.50	x. ± 5°	REV.	A	TITLE	SD No Push H2.80-2 conn.	CHECKED		东莞市欧联电子科技有限公司 DONGGUAN OLN ELECTRONICS TECHNOLOGY CO., LTD.			
.x±0.25	.x ± 2°	SIZE		SHEET	2 OF 2	APPROVED					
.xx±0.15	.xx ± 1°	A4									